

Corrugating Rolls Identification

Please fill out this editable PDF form with your computer only to avoid reading error. Once completed, send to info@corrogo.shop

If you have the drawing, please send to us directly. If not, please complete the following form:

Machine Name: _____ Date of Machine Made: _____

Machine Model: _____ OEM /Serial No. (if available): _____

Identify which Roll? Corrugating Roll Pressure Roll Glue Roll Doctor Roll

1. Roll Dimension information:

A. Length: _____ mm; B. Diameter: _____ mm;

3. Flute Profile information(for corrugating rolls only):

Flute Type: _____; Height: _____ mm; Pitch: _____ mm; Coating: Carbide Chrome

4. Shaft End information:

C. : _____ mm; D. : _____ mm; E. : _____ mm; F. : _____ mm;

G. : _____ mm; H. : _____ mm; I. : _____ mm; J. : _____ mm;

K. : _____ mm; L. : _____ mm; M. : _____ mm; N. : _____ mm;

O. : _____ mm; P. : _____ mm; Q. : _____ mm; R. : _____ mm;

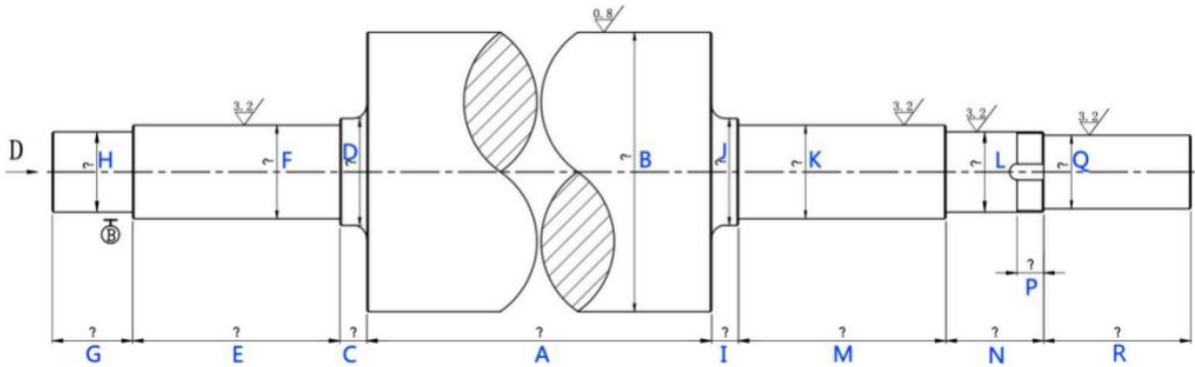

Shaft ends may be different, please sketch, note any special features or send us pictures:

Any special requirements you may have: _____.

Company Name: _____ Completed By: _____

Order ID: _____ Email: _____ Date: _____