

MRS Brake Flange Installation Identification

Please fill out this editable PDF form with your computer only to avoid reading error. Once completed, send to info@corrogo.shop

If you have the drawing, please send to us. If not, complete this form per the below information:

Machine Name: _____ Date of Machine Made: _____

Corrugator Width: _____ mm; Corrugator Speed: _____ m/min

Max Paper Roll ϕ : _____ mm; Ordered Brake Model: _____

Flange dimension information:

A. _____ mm; B x C : _____ mm; D. : _____ mm;

E. : _____ mm; F. : _____ mm; G. : _____ mm;

H. : _____ mm;

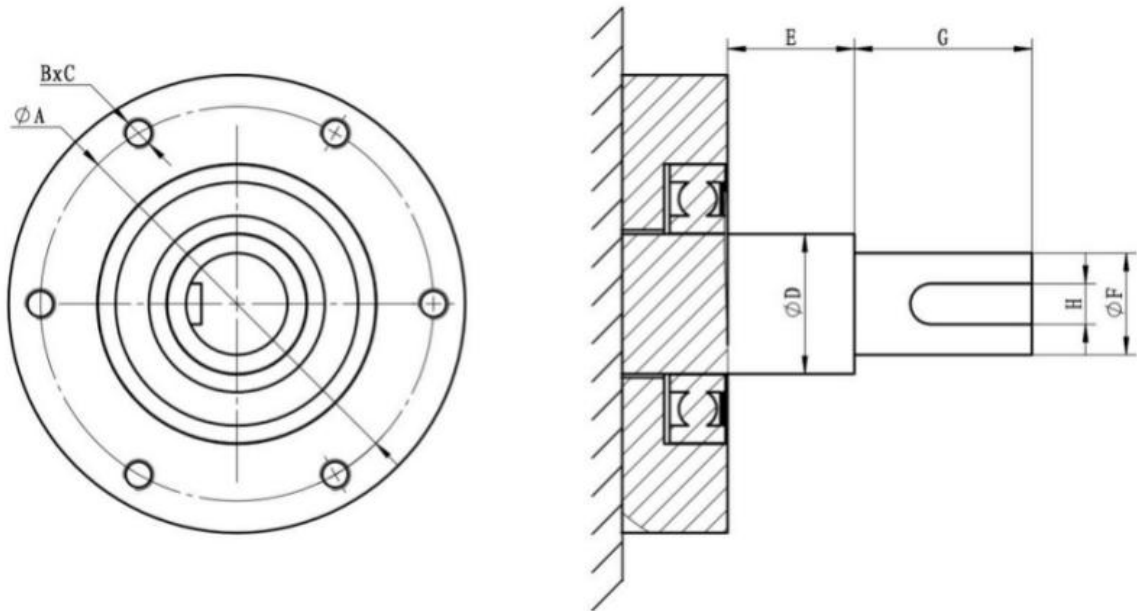

Please sketch or note any special features:

Any special requirements you may have: _____.

Company Name: _____ Completed By: _____

Order ID: _____ Email: _____ Date: _____